



# MB-3

---

## OIL IGNITION SYSTEM



Safe-Fire's MB-3 oil igniter is specially designed for boilers burning higher ash content coal or operating in harsh environments.

**MB-3 Igniter** resists erosion from the harsh secondary air and delivers smooth and trouble free ignition for large coal-fired boilers, particularly tangential firing types. Using oil as the fuel, the MB-3 provides the versatility and efficiency of a mechanically or air & steam atomized igniter, suitable for burner ignition and burner stabilization.

**The MB-3 Igniter** is developed using Safe-Fire's world-class R&D to ensure high reliability, quality and efficiency for applications where safety and dependability are paramount.



## FEATURES

- Smooth, jam free extension/retraction
- Reliability and maintenance ensured by separately-arranged solenoid valve cabinets
- Rigid / flexible versions available
- Class 1, Class 2, Class 3 or Class 3 special capacities



## DIMENSIONS

### MB-3 OIL IGNITER ASSY.

(Rigid Type)

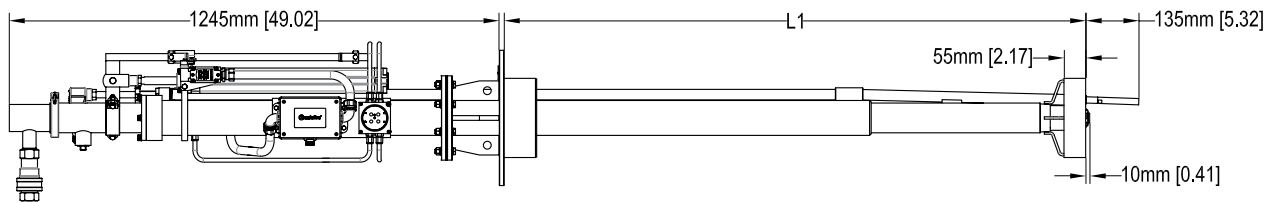

Mechanical-Atomizing

### MB-3 OIL IGNITER ASSY.

(Flexible Type)

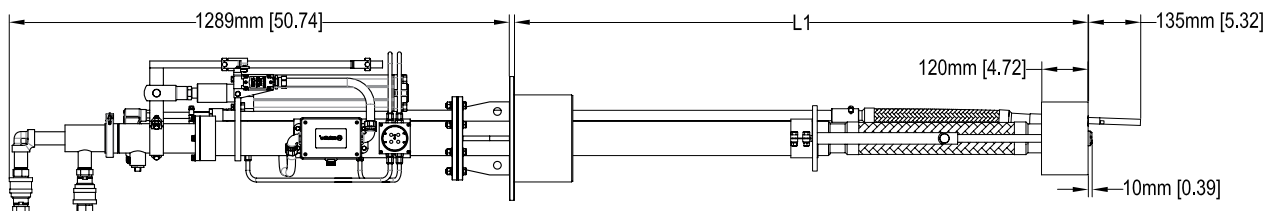

Steam-Atomizing/Air-Atomizing

L1: as required.

DIMENSIONS



**HESI POWER PACK**  
S-80-02 (120Vac/220Vac, 50/60Hz)

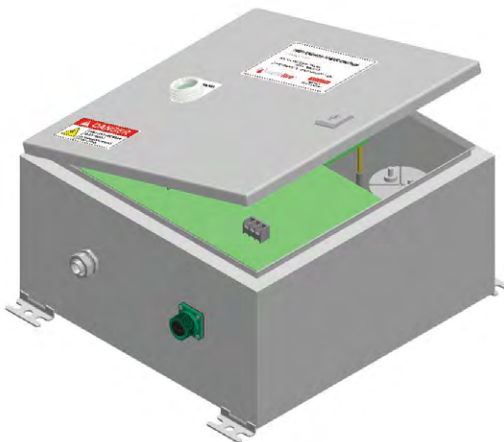
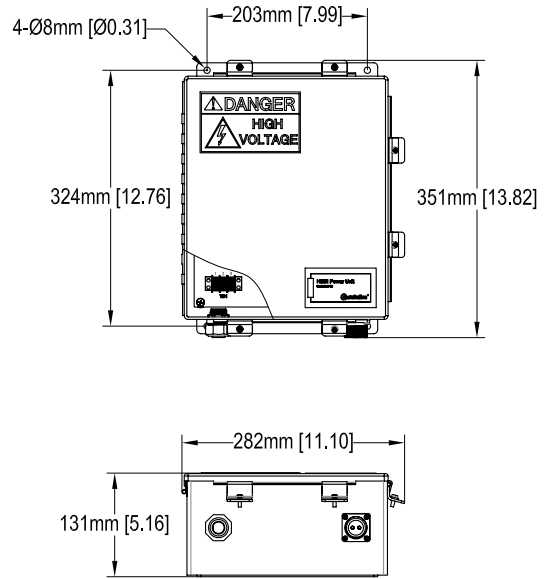

**HESI POWER PACK**  
S-80-02 A (120Vac, 60Hz)  
S-80-02 C (220Vac, 50Hz)

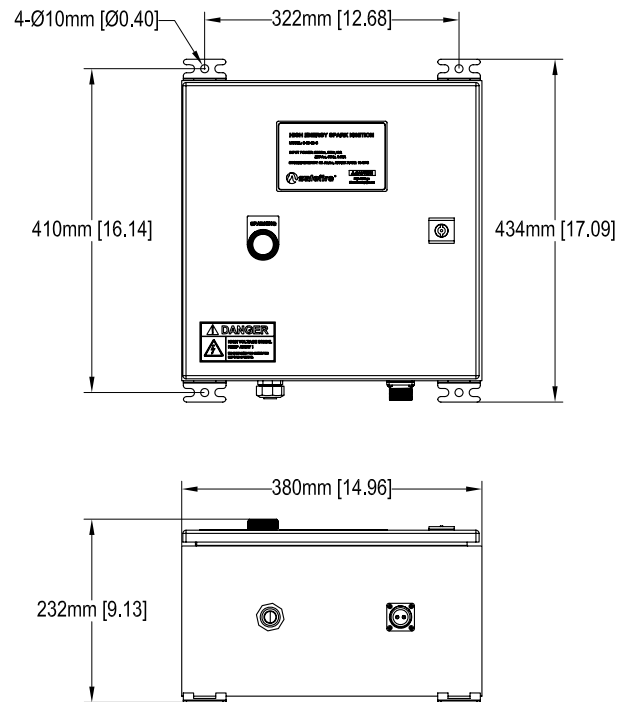



## DIMENSIONS

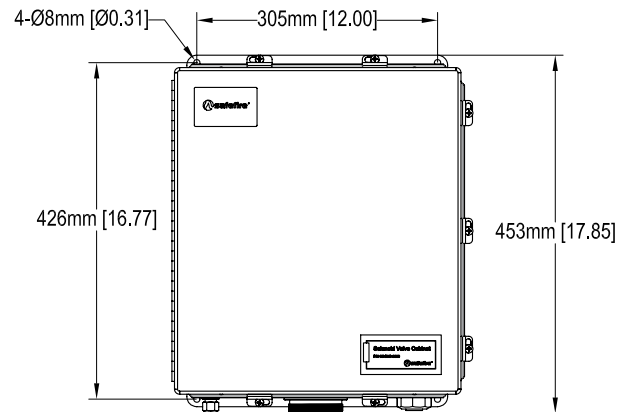

### SOLENOID VALVE CABINET

SVC-01(Right Hand)

SVC-02(Left Hand)

SVC-05(Right Hand)

SVC-06(Left Hand)

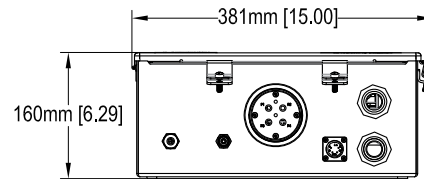

### AIR HOSE ASSY.

AH-45(L=4.5m)

AH-60(L=6.0m)

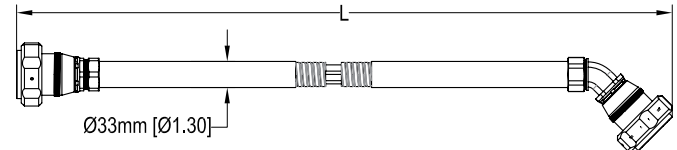
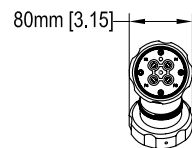

### HIGH VOLTAGE CABLE ASSY.

HCAB-245(L=4.5m)

HCAB-260(L=6.0m)

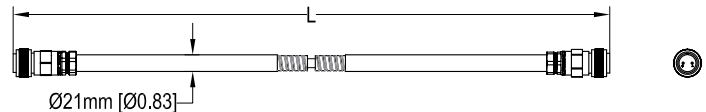
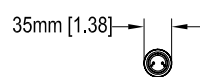

## DIMENSIONS



### CONTROL CABLE ASSY.

CCAB-545(L=4.5m)

CCAB-560(L=6.0m)

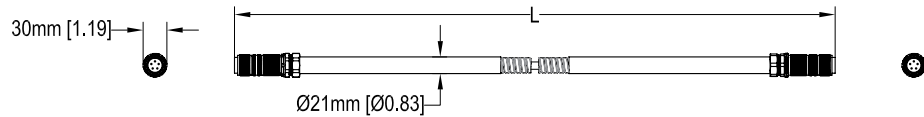

## TECHNICAL DATA

### MB-3 OIL IGNITER

BTU RATING	16-160MBTU
FUEL TYPE	Light diesel oil, Crude oil, Heavy oil
FUEL VISCOSITY	≤4°E (≤30 cSt)
FUEL PRESSURE	2.0 to 3.5 MPa (Mechanical-Atomizing) 1.0 to 2.0 MPa (Steam-Atomizing/Air-Atomizing)
ATOMIZING AIR/STEAM PRESSURE	0.6 to 1.0 MPa
COOLING AIR REQUIREMENTS	150 m <sup>3</sup> /Hr.@ 1.5KPa
ACTUATOR TYPE	Pneumatic
COMPRESSED AIR PRESSURE	0.4 to 0.8 MPa
AMBIENT TEMPERATURE	-20°C to +70°C (No freezing)

### HESI POWER PACK

CAPACITY	20J, 33J
ENCLOSURE TYPE	NEMA 4, 4X, IP6
CONNECTION	MS3102A
INPUT POWER	110/220Vac, 50/60Hz
SPARK RATE	8-15SPS
OPERATING TEMPERATURE	-25°C to +75°C



## HOW THE MB-3 IGNITION SYSTEM WORKS...

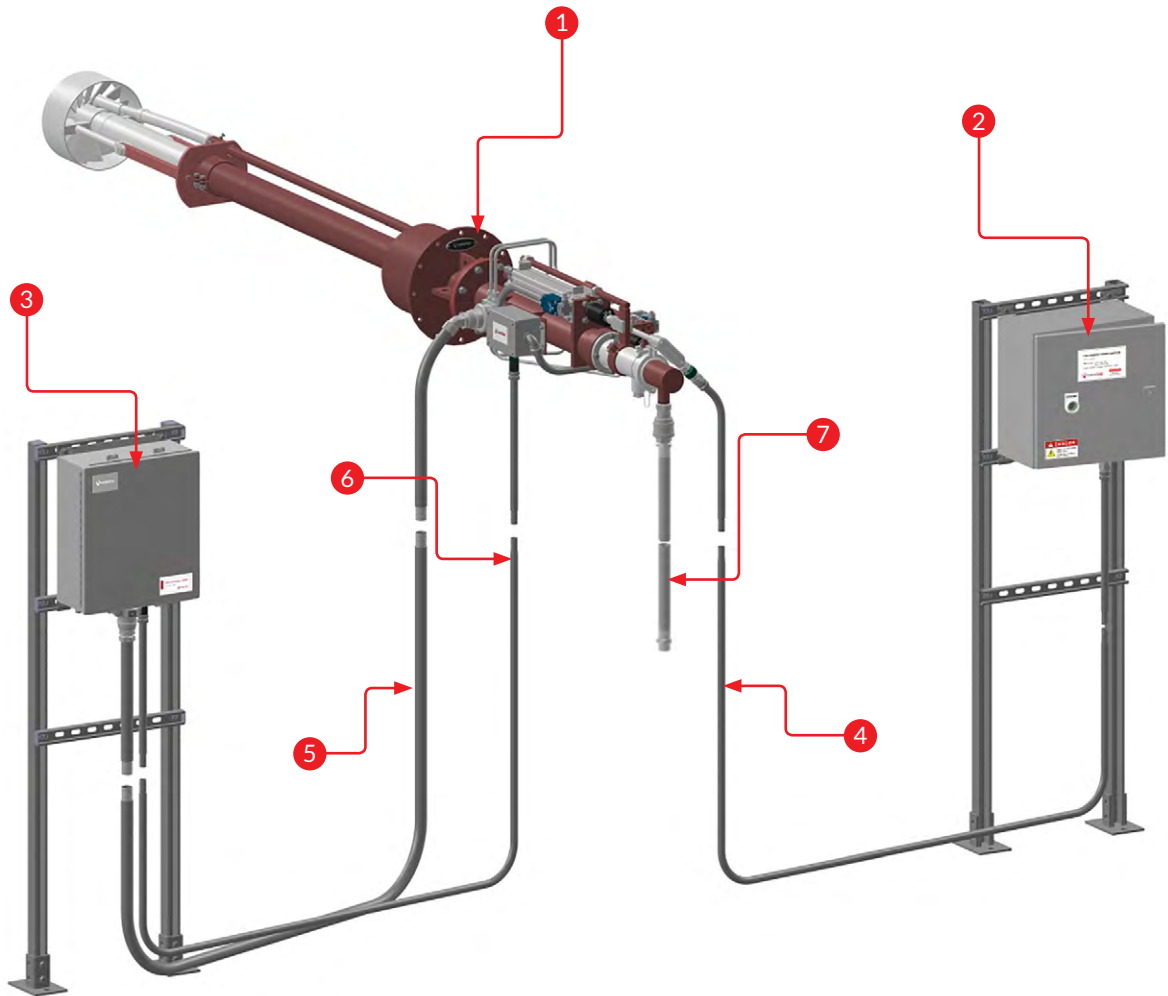

1 MB-3 Oil Igniter

2 HESI Power Pack

3 Solenoid Valve Cabinet

4 High Voltage Cable

5 Air Hose Assy.

6 Control Cable Assy.

7 Flexible Metal Hose

## MB-3 OIL IGNITER INSTALLATION

### TANGENTIAL FIRING BOILER APPLICATION

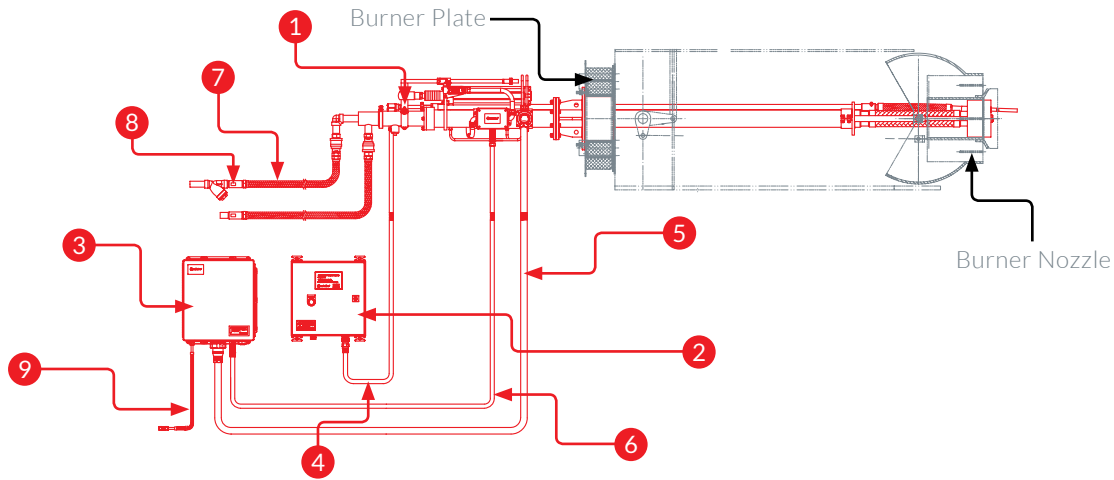

- |                          |                   |                            |
|--------------------------|-------------------|----------------------------|
| 1 MB-3 Oil Igniter       | 2 HESI Power Pack | 3 Solenoid Valve Cabinet   |
| 4 High Voltage Cable     | 5 Air Hose Assy.  | 6 Control Cable Assy.      |
| 7 1" Flexible Metal Hose | 8 Pipe Nipple     | 9 1/4" Flexible Metal Hose |

### WALL-FIRED BOILER APPLICATION

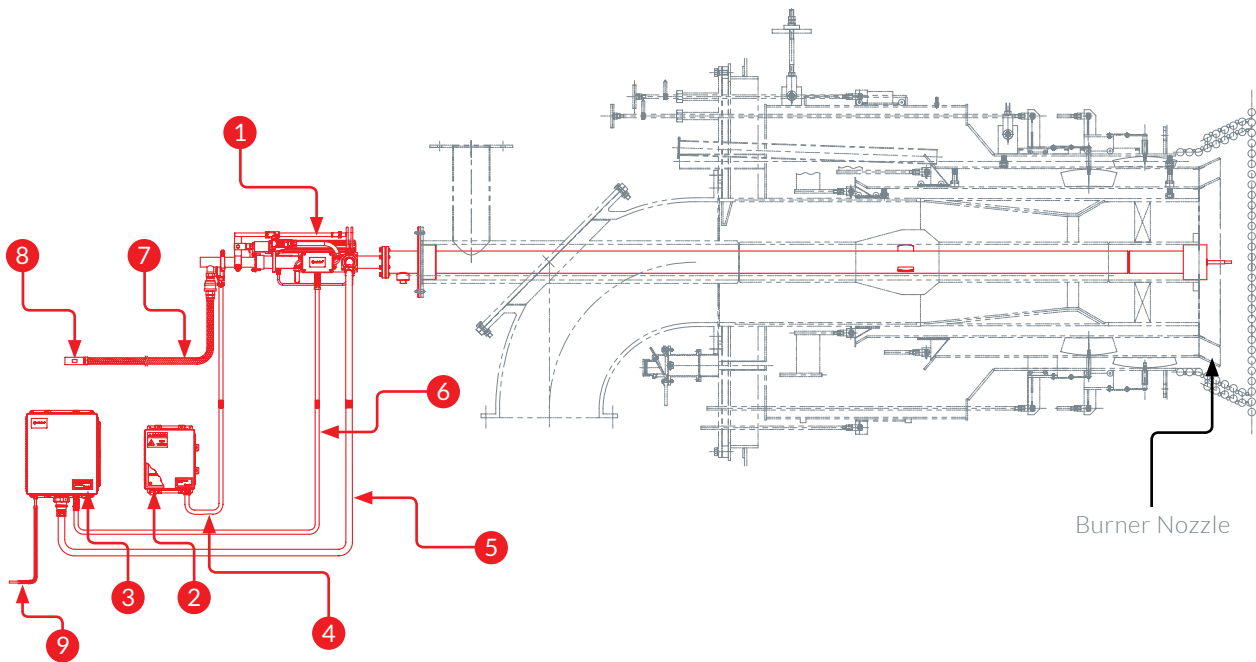

- |                          |                   |                            |
|--------------------------|-------------------|----------------------------|
| 1 MB-3 Oil Igniter       | 2 HESI Power Pack | 3 Solenoid Valve Cabinet   |
| 4 High Voltage Cable     | 5 Air Hose Assy.  | 6 Control Cable Assy.      |
| 7 1" Flexible Metal Hose | 8 Pipe Nipple     | 9 1/4" Flexible Metal Hose |



## MB-3 IGNITION SYSTEM INSTALLATION

### ARCH-FIRED BOILER APPLICATION

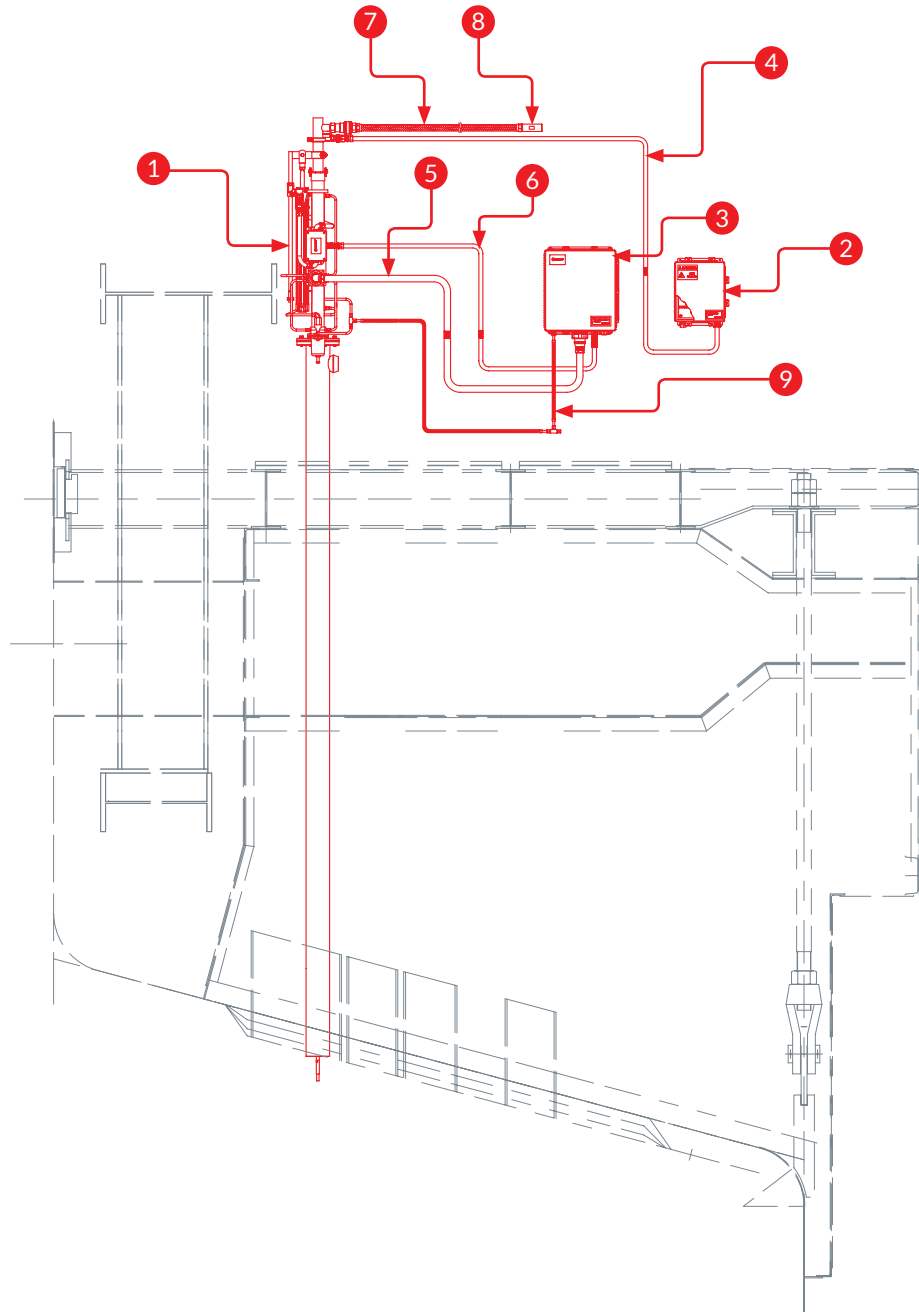

- |                          |                   |                            |
|--------------------------|-------------------|----------------------------|
| 1 MB-3 Oil Igniter       | 2 HESI Power Pack | 3 Solenoid Valve Cabinet   |
| 4 High Voltage Cable     | 5 Air Hose Assy.  | 6 Control Cable Assy.      |
| 7 1" Flexible Metal Hose | 8 Pipe Nipple     | 9 1/4" Flexible Metal Hose |



# HESI POWER PACK ELECTRICAL CONNECTION

## 1) S-80-02

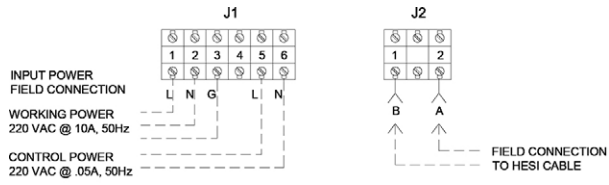

## 2) S-80-02 A

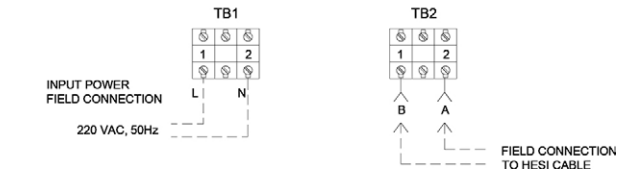
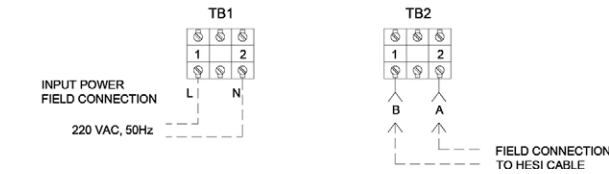
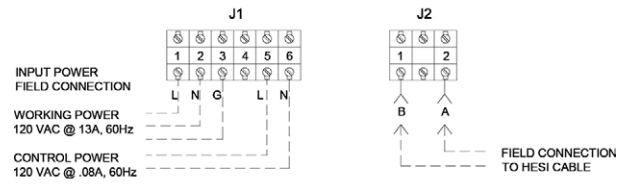
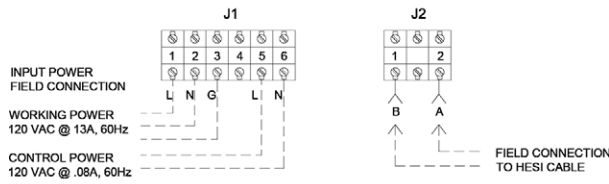
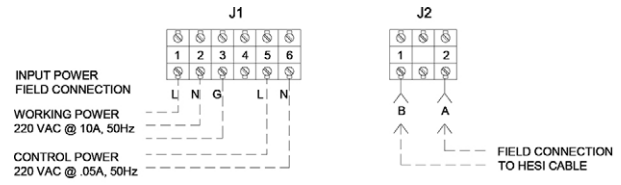

## 2) S-80-02 C

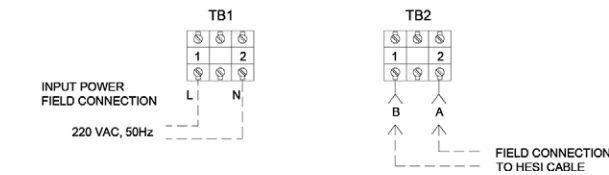
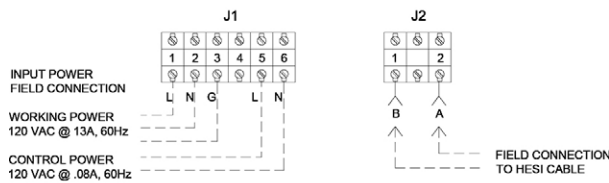
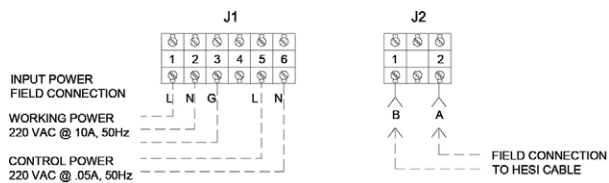



## SOLENOID VALVE CABINET ELECTRICAL CONNECTION

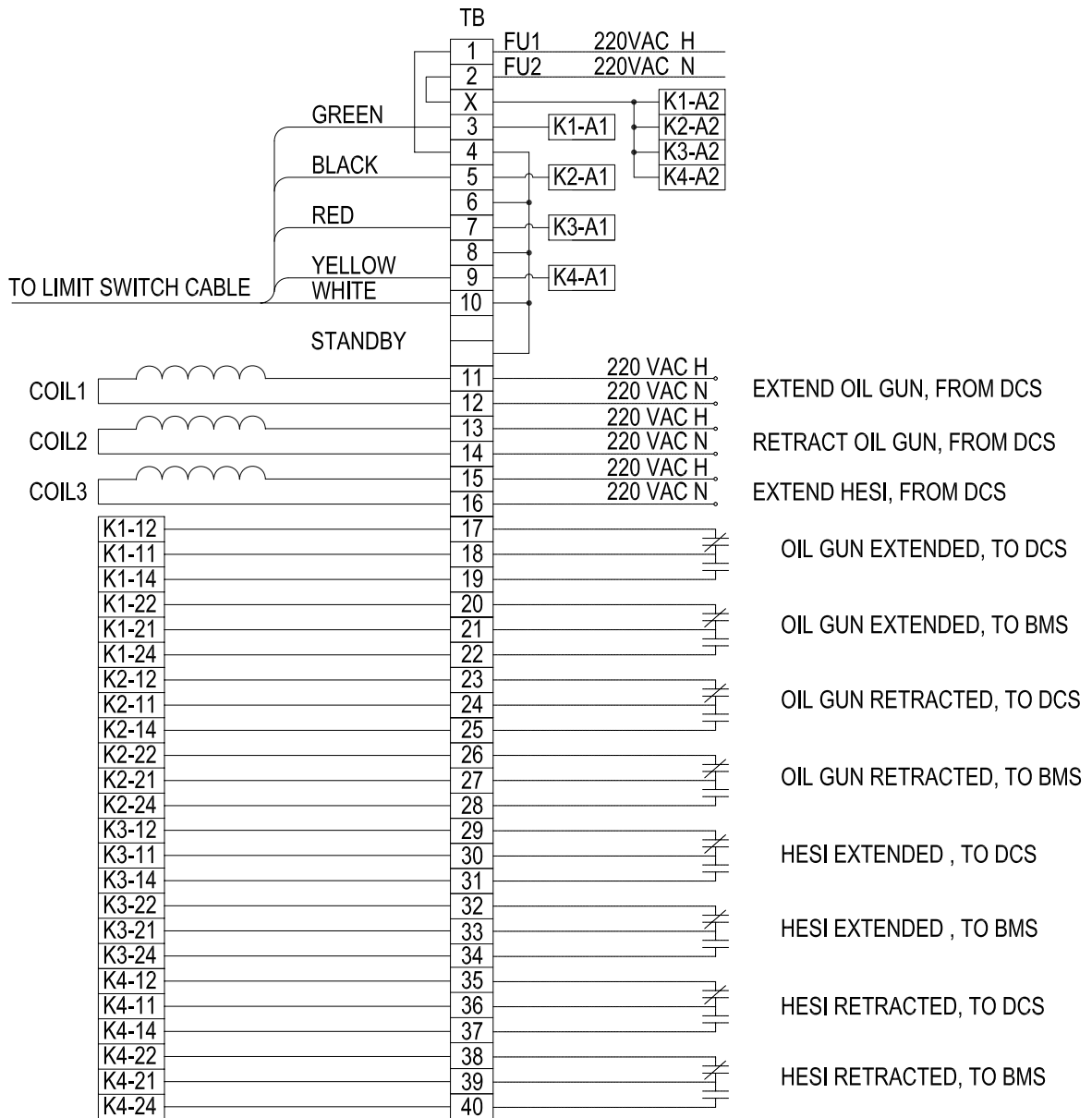

## MB-3 IGNITION SYSTEM ORDERING DATA

P/N	DESCRIPTION	NOTES
65-HSI-0013	S-80-02 HESI POWER PACK, 20J, 220-240VAC, 50/60Hz.	
65-HSI-0232	S-80-02 HESI POWER PACK, 20J, 110-120VAC, 50/60Hz.	
65-HSI-0074	S-80-02 A HESI POWER PACK, 33J, 120VAC, 60Hz.	
65-HSI-0143	S-80-02 C HESI POWER PACK, 33J, 220VAC, 50Hz.	
65-SVC-0001	SOLENOID VALVE CABINET FOR RIGHT HAND IGNITER. 0.1 to 0.7MPa	
65-SVC-0002	SOLENOID VALVE CABINET FOR LEFT HAND IGNITER. 0.1 to 0.7MPa	
65-SVC-0005	SOLENOID VALVE CABINET FOR RIGHT HAND IGNITER. 0.05 to 0.85MPa	
65-SVC-0006	SOLENOID VALVE CABINET FOR LEFT HAND IGNITER. 0.05 to 0.85MPa	
65-HVC-0042	HIGH VOLTAGE CABLE ASSY. 4.5 METERS LONG.	
65-HVC-0039	HIGH VOLTAGE CABLE ASSY. 6.0 METERS LONG.	
65-AHS-0041	AIR HOSE ASSY. 4.5 METERS LONG	
65-AHS-0089	AIR HOSE ASSY. 6.0 METERS LONG	
65-CAB-0040	CONTROL CABLE ASSY. 4.5 METERS LONG.	
65-CAB-0088	CONTROL CABLE ASSY. 6.0 METERS LONG.	
45-300-0330	1" FLEXIBLE METAL HOSE, 1"NPT TUBE FITTINGS, 1.5M LG.	
45-300-0492	1" FLEXIBLE METAL HOSE, NPT TUBE FITTINGS, 2.0M LG.	
45-300-0331	1/4" FLEXIBLE METAL HOSE, 3/8 OD STEM, 1.5M LG.	
45-300-0352	1/4" FLEXIBLE METAL HOSE, 3/8 OD STEM, 4.5M LG.	
45-300-0333	PIPE NIPPLE, 1" NPT FEMALE x 38MM OD BUTT-WELD	

## **SAFE-FIRE GROUP**

[www.safe-fire.com](http://www.safe-fire.com)

### **UNITED STATES**

#### **Safe-Fire Inc.**

5354 Irwindale Avenue Unit B,  
Irwindale , CA 91706

T: 1 626 960 3800

F: 1 626 960 4100

E: [info@safe-fire.com](mailto:info@safe-fire.com)

#### **Safe-Fire Innovations LLC**

5600 Tennyson Parkway Suite 270,  
Plano, TX 75024

T: 1 972-999-9328

F: 1 972-473-2300

E: [info@safe-fire.com](mailto:info@safe-fire.com)

### **AUSTRALIA**

#### **Safe-fire Pty Ltd.**

Level 1 , 1 Queens Road, Melbourne, VIC 3004

E: [info@safe-fire.com](mailto:info@safe-fire.com)

### **CHINA**

#### **Safe-fire (Shanghai)**

#### **Industry Equipment Co., Ltd**

2325 Duhui Road, Shanghai, Zip: 201108

T: 86 21 64425576

F: 86 21 64420102

E: [info@safe-fire.com.cn](mailto:info@safe-fire.com.cn)

#### **Sunman Control Engineering (Shanghai) Co., Ltd**

7F, Building A,  
New Caohejing International Business Centre  
391 Guiping Road, Shanghai 200233, China

T: 86 21 54971800

F: 86 21 54971801

E: [info@smcontrol.com](mailto:info@smcontrol.com)

